

Smart Lifestyle Massage Chair



Vita

More Freedom to Live Smartly

Made  Japan



The Family Inada Philosophy

Right since its inception in 1962, Family Inada has been focused on building massage chairs that can be used in every home. As a leading massage chair manufacturer, we continuously invest in the research and development of mechanisms and innovative products.

Massage chairs were first introduced to the world as an entertaining device at bathhouses that people had to feed coins into to enjoy a relaxing massaging experience. Later, in 2000, we went from developing massage chairs that provide temporary relief from muscle stiffness to chairs that promote good health through daily care. It was in 2016 that we developed the industry's very first massage chair with "Artificial Intelligence Mechanism".

In 2020, we were finally able to meet our goal by completing "Inada Vita", a compact, lightweight and low-cost massage chair equipped with technology attained over 50 years. The 2-way specifications and the optional chair stand make it possible to install this chair in any room a person wishes to. At Family Inada, we are confident that Inada Vita is the answer to today's need for daily body-care.

Luxurious body-care chair that blends into your lifestyle

Developed using a new concept, Inada Vita is a unique massage chair that gives you the freedom to enjoy a relaxing massage in the comfort of your own home. You no longer need to go to a professional masseuse; with this massage chair, you can stay active all day, keeping everyday stress and fatigue at bay.



Sofa-like massage chair

Equipped with advanced AI (Artificial Intelligence) technology, Inada Vita not only offers a comfortable sitting option but also excellent massage comfort. It comes with an entire lineup of massage programs that you can select from, depending on the level of fatigue you experience and your lifestyle.

- ◆ Homemakers caring for their families
- ◆ People with busy work schedules
- ◆ Senior citizens looking to enjoy life after retirement



Mechanism that suits the body

Inada Vita's unique, built-in "double engine" allows it to differentiate between the upper body and the lower body, offering a mechanism that is highly compatible with the human body. The "true essence of massaging" is attained thanks to these upper and lower AI mechanisms.

Back Mechanism (Neck to Waist)

Using the AI Android Mechanism, four rollers gently massage the splenius muscle as per your physical characteristics, level of stiffness and fatigue. The firm and light massaging experience closely resembles that of a professional masseuse.

Leg Mechanism (Thigh Base to Calf / Ankle)

Equipped with 44 Shiatsu points, the AI Annular Deep Massaging Mechanism securely grips your calf over a wide area for a relaxing massage. You can also focus on your thigh base by choosing massage programs that are designed to promote lymphatic flow.

Massages according to your physical condition

Inada Vita's AI mechanism is designed to adjust the massage operation as per a person's muscle shape and size and the level of stiffness at that moment. The strength, time and speed of the movement of the rollers depend on the load received during a massage. While the stiff areas are massaged deeply and slowly, once relaxed, they are massaged rhythmically.

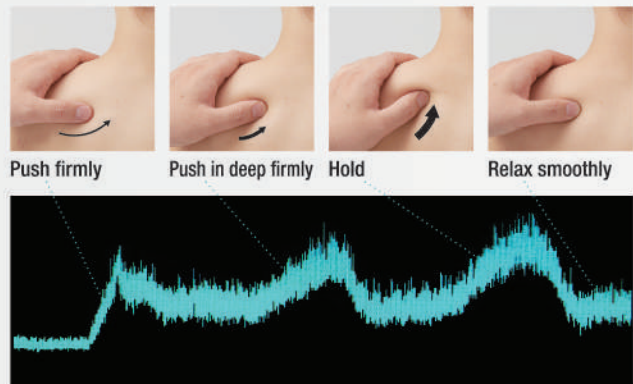

Strong & Firm

The parts of your body that require some force, such as your back, hips and calves, are massaged strongly and firmly. Firm pressure is also applied while massaging your thigh and neck muscles.

Light & Gentle

Thick blood vessels are concentrated at the base of the thighs, and daily care for this area is important to ensure proper blood circulation, especially if you tend to sit all day and do not have much time to exercise. Deep massage to the area between your thigh base and buttocks can improve your blood circulation significantly.



*Relax & unwind anytime
with Inada Vita*



AI controlled massage

Inada Vita's AI mechanism allows the chair to control the level of massage comfort. It is designed to match the massaging comfort to a specific user and the level of stiffness experienced in specific areas of their body. It uses centripetal and centrifugal methods to offer you a massaging experience that is on par with that of a professional masseuse.

◆ Centripetal Method

Centripetal Method helps improve blood circulation from one end of the body to the centre.

◆ Centrifugal Method

Centrifugal Method helps enhance blood circulation from the centre of the body to one end.

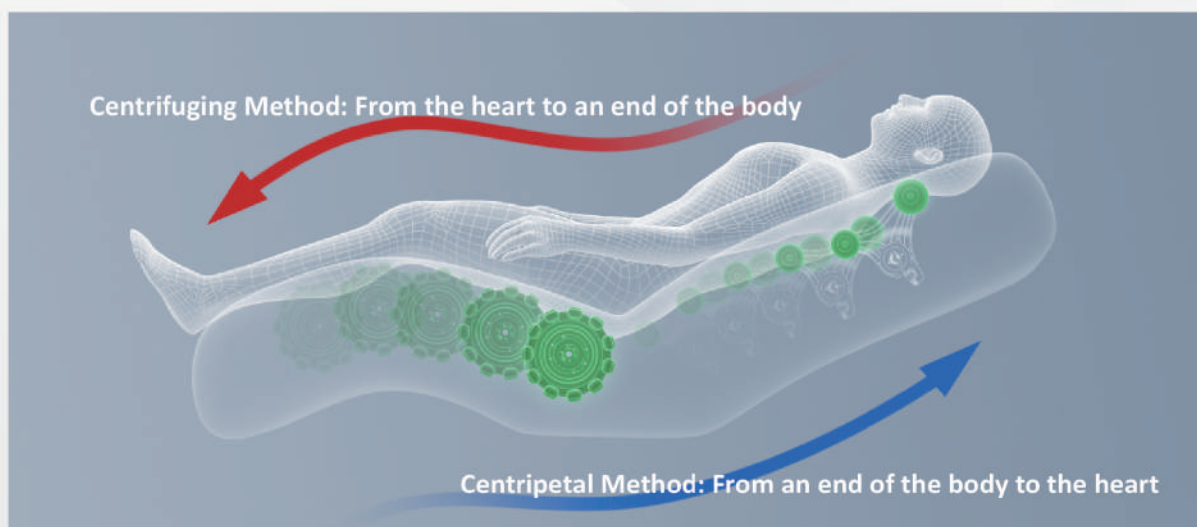

Intensive massage for areas that experience much fatigue

◆ Lower Body:

The leg mechanism not only offers firm massage between the thigh base and the calf but also around the ankles.

◆ Neck & Shoulders:

While the leg mechanism supports the thigh base, the chair also massages stiff shoulders from above.

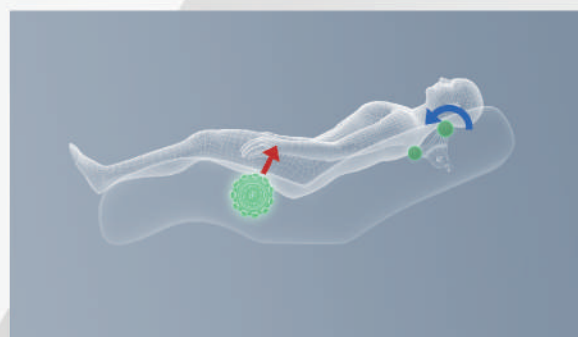
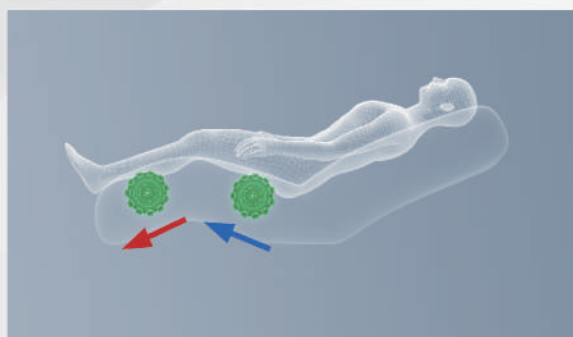

Programs that incorporate professional massaging techniques

◆ Morning Session:

This program focuses on blood and lymphatic flow and works on the parasympathetic nerves. It helps relieve stress and fatigue.

◆ Full Body:

This program involves combined movement of the upper and lower mechanisms to offer a well-balanced massage that promotes better blood flow in the body.

◆ Upper Body:

During this program, the upper body mechanism focuses on firmly massaging your neck, shoulders, back and hips.

◆ Soft Mode:

This program allows you to opt for a soft, soothing massage to your lower body.

◆ Night Session:

This program focuses on promoting systemic blood flow, activating your body quickly by working on the sympathetic nerves. It helps bring about a more positive feeling.

◆ Neck & Shoulders:

This program focuses on the neck and the shoulder area and is highly recommended for people who have a lot of desk work or housework.

◆ Lower Body:

During this program, the lower body mechanism focuses on massaging the area from your thigh base to your calves and ankles. This program is recommended for those who suffer from tired feet.



Mr. Hideyo Matsuura: Massage Supervisor

Mr. Hideyo Matsuura, Director of Matsuura Acupuncture Clinic and a Visiting Professor of Kansai University of Health Sciences, has a reputation for being one of Japan's leading therapists. He has been a leader in the field of acupuncture for over 40 years and is recognised as the "Therapist with the Hand of God".



High - Quality Design

Inada Vita is designed to easily fit into any living space, be it the living room, dining room, bedroom, or any other room you choose to place it in. For all those who need it, the chair comes with an optional, dedicated chair stand.





Compact & Lightweight

Inada Vita's compact size makes it possible for you to install it in any room and enjoy all its massage functions. Being lightweight, approx. 26 kgs (57 lbs.), you can freely and easily rearrange it whenever the mood strikes.



Enjoy a relaxing massage at home with Inada Vita

History of Massage Chairs by



1962

◀ Family Chair

A standard massage chair that administers massage at a constant speed. The rising and lowering of rollers is adjusted through handle operations in this chair.



2000

◀ Inada Chair

A massage chair built with an aim to help relieve stress and fatigue and improve health. The chair comes with an automatic Shiatsu point detection system that uses light sensors and offers a relaxing massage through three mechanisms.



2018

◀ Family Inada Therapina / Robo Massage Chairs

An advanced massage chair that utilises AI hybrid mechanism to provide massage comfort very similar to that of a human hand. With this massage chair, one can use a communication network to manage the health of the entire family, on a daily basis.



2020

◀ Family Inada Vita Massage Chair

A massage chair built with an aim to help relieve stress and fatigue and improve health. The chair comes with an automatic Shiatsu point detection system that uses light sensors and offers a relaxing massage through three mechanisms.

Color Variation



Remote Controller Holder

*The photo shows as ivory (IV) chair.



Chair Stand



Silver (SV)

Specifications

Sales Name	Inada Chair Vita
Model No	HCP - VT200
Accessories	Power Cord
Reclining Angle	Approx. 115° to 169° relative to the horizontal plane Stepless (electric reclining)
Exterior Fabric	Synthetic Leather (BK), (IV), (RD) / Fabric (GR), (CW)
Power Supply	110-240 V AC 50 - 60 Hz
Rated Powder Consumption	75W
Weight	Approx. 26 kg (57 lbs.)
Manufacturer Warranty Period	One Year

Vita Series Option

Product Name	Chair Stand
Model No	OP - VT001
Material	Iron (Chrome Plating / Baked Paint)
Weight	Approx. 8kg (18 lbs.)
Adaptive Weight	100 kg (220 lbs.)
Manufacturer Warranty Period	One Year

Dimensions

Chair Dimensions



* Numbers in parentheses represent the dimension when the chair is fully reclined.

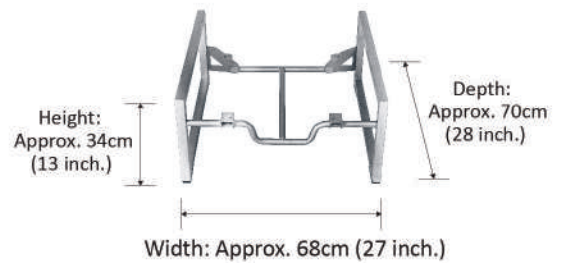

Carrying into and installing in your home

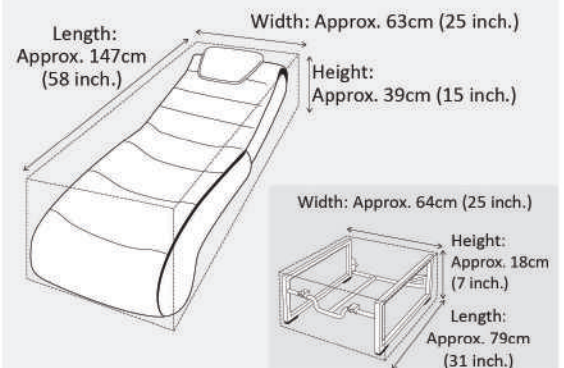

Made  Japan



Swan Global Trading LLC

Office135, 1st Floor, Regus Building,
D Ring, Po Box 32522, Doha, Qatar.
sales@swangt.com | + 974 44231295

inada.in